



FINAL YEAR PROJECT 2012/2013

GPS and GSM based Vehicle Tracking
System

BY

**Muzammil Behzad
Muhammad Mahboob Alam**

**Supervised By:
Dr. Mahmood Ashraf**

Introduction

- ▶ Problems of traffic organization, vehicles theft and surveillance.
- ▶ A tracking system which will be installed in the vehicle and will give the location info and control of the vehicle to the owner.

Objectives

- Locate the vehicle
- Control the vehicle
- Monitor the vehicle
- Engine power cutoff via SMS
- Cost effective System

Applications

• Remote Wireless Monitoring of speed and location

• Fleet management

• Wireless data transmission

• Worldwide Cover Operation

• Vehicle's Speed, Location, Water Level, Engine Status, Door's Status

• Motorway Service

• Ambulance Service

Work Flow Diagram



Block Diagram

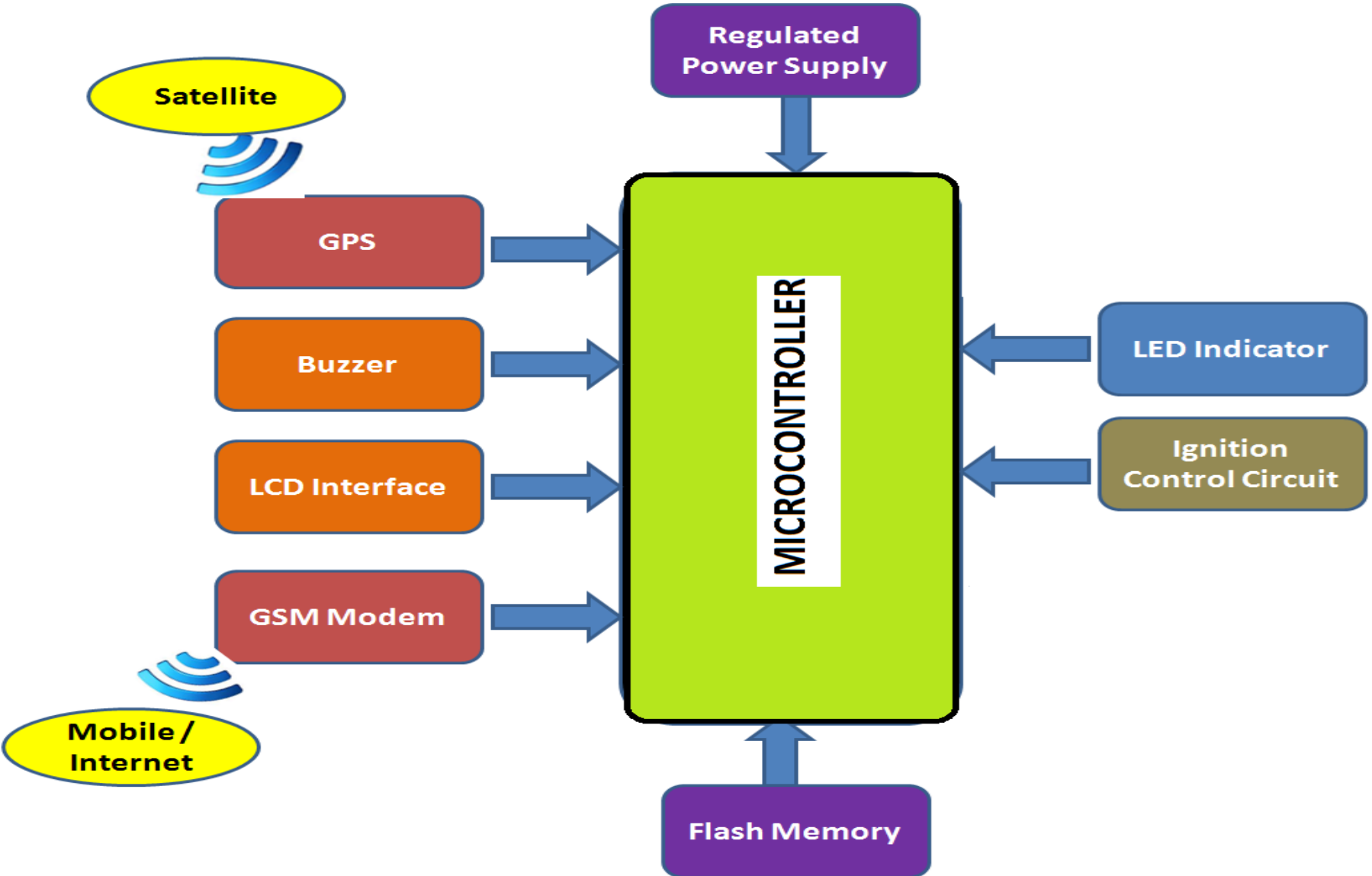

Project Phases

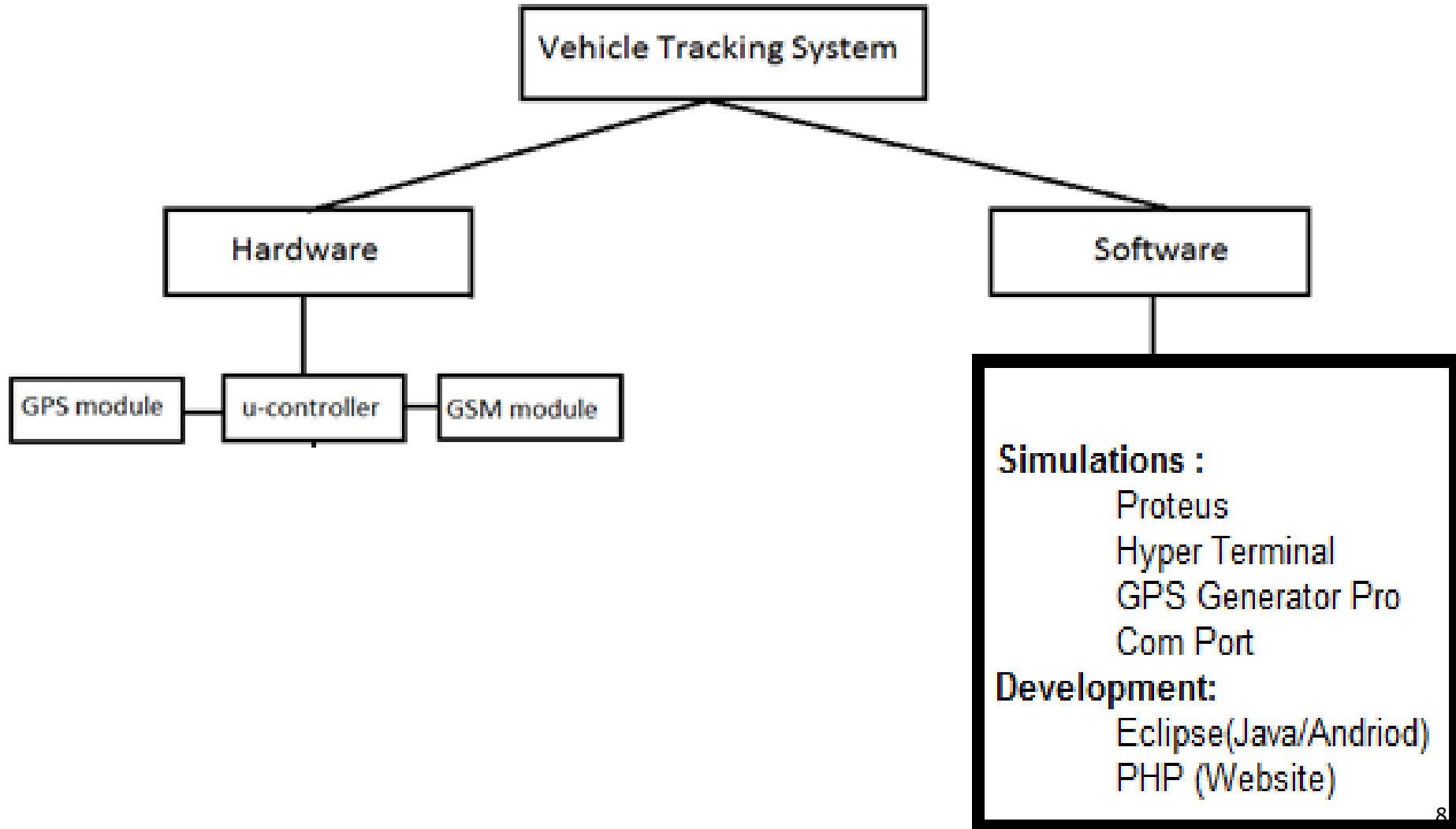

Modules / Components

Microcontroller ATMEGA16

GPS module EM-406A

GSM Module SIM 900D

LCD Display 16 x 2

Battery 12V

LED/Buzzer Indicators

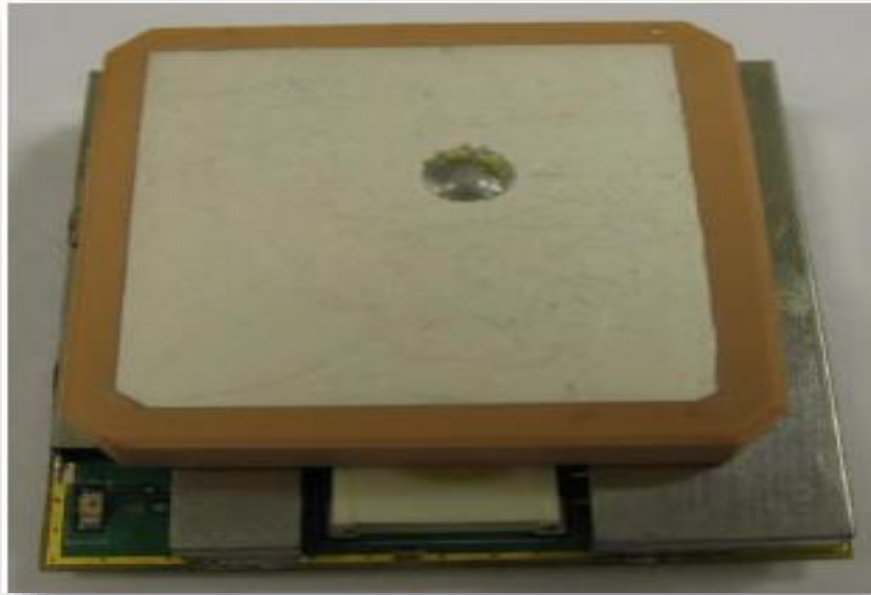

Interfacing GPS with MICROCONTROLLER

GPS in Our Project

▶ GPS Module – EM-406A

- Frequency 1575.42 MHz
- Accuracy 5m
- Altitude 60000 ft.
- Velocity 515 m/s
- Voltage 4.5 V – 6.5 V
- Current 44 mA
- Baud rate 4800

Simulations

- GPS Generator PRO
- Proteus
- Virtual ComPort
- Hyper Terminal

GPS Generator PRO

Avangardo GPS Generator Pro

File Input Mode Data Transmission Operations Help

Show all Mirror Tracking Calculate CRC RMC GGA GLL GSA GSV VTG GPS fix

Map Mode File Mode Route Mode

Open Map File... GPS Simulation

High speeds

Speed: 40

kph knots mph

Altitude, m: 100,00

Start point

Latitude: 17 ° 20,4643 ' N

Longitude: 9 ° 56,7369 ' E

(double click map to setup)

Map Satellites Constellation

2°00,00'W 26°00,00'W 0°00,00'E 26°00,00'E 52°00,00'E 78°00,00'E

52°00,00'N

26°00,00'N

78°00,00'N

NMEA output

----- CUT HERE -----

- NMEA log file from Avangardo GPS Generator

- <http://avangardo.com>

----- CUT HERE -----

```
$GPRMC,175559.97,A,1346.257,N,02039.377,E,21.60,0.00,040809,0.0,E,A*0A
$GPRMC,175600.97,A,1346.258,N,02039.371,E,21.60,283.37,040809,0.0,E,A*01
$GPRMC,175831.64,A,1720.464,N,00956.743,E,21.60,96.43,040809,0.0,E,A*3E
$GPRMC,175832.64,A,1720.463,N,00956.749,E,21.60,96.43,040809,0.0,E,A*30
$GPRMC,175833.64,A,1720.462,N,00956.755,E,21.60,96.43,040809,0.0,E,A*3D
```

lon: 9°26,14'W; lat: 57°07,41'N

Proteus (Results)

The screenshot displays the Proteus ISIS Professional (Animating) interface. A Virtual Terminal window is open, showing a series of NMEA sentences in green text on a black background. The sentences are:

```
$GPGSA,A,3,19,23,27,28,6.6,2.4,6.2*36
$GPRMC,115539.000,A,3134.6700,N,07421.4652,E,0.62,163.53,280607,.,A*68
$GPGGA,115539.000,3134.6700,N,07421.4652,E,1.04,2.4,209.7,M,-37.5,M,0000*75
$GPGSA,A,3,19,23,27,28,6.6,2.4,6.2*36
$GPRMC,115539.000,A,3134.6700,N,07421.4652,E,0.62,163.53,280607,.,A*68
$GPGGA,115539.000,3134.6700,N,07421.4652,E,1.04,2.4,209.7,M,-37.5,M,0000*75
$GPGSA,A,3,19,23,27,28,6.6,2.4,6.2*36
$GPRMC,115539.000,A,3134.6700,N,07421.4652,E,0.62,163.53,280607,.,A*68
$GPGGA,115539.000,3134.6700,N,07421.4652,E,1.04,2.4,209.7,M,-37.5,M,0000*75
$GPGSA,A,3,19,23,27,28,6.6,2.4,6.2*36
$GPRMC,115539.000,A,3134.6700,N,07421.4652,E,0.62,163.53,280607,.,A*68
$GPGGA,115539.000,3134.6700,N,07421.4652,E,1.04,2.4,209.7,M,-37.5,M,0000*75
$GPGSA,A,3,19,23,27,28,6.6,2.4,6.2*36
$GPRMC,115539.000,A,3134.6700,N,07421.4652,E,0.62,163.53,280607,.,A*68
```

The background shows a circuit diagram with a component labeled "AT8801" and "TBCD". A legend on the right lists pins P1.0 through P1.7 and P2.6/A14 through P2.7/A15. A status bar at the bottom indicates "5 Message(s)" and "PAUSED: 00:00:23.750000".

Hyper Terminal (Results)

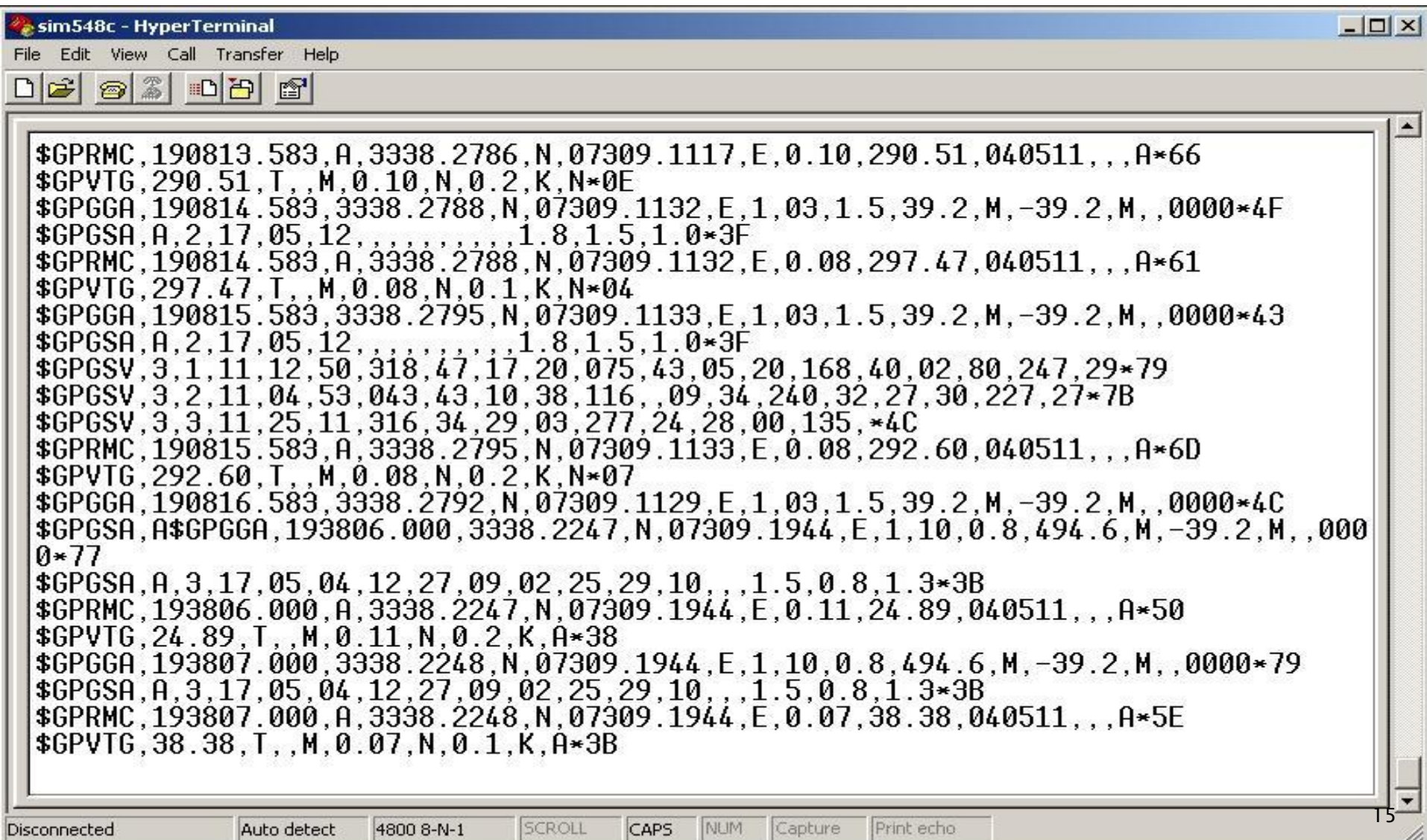

```
sim548c - HyperTerminal
File Edit View Call Transfer Help

$GPRMC,190813.583,A,3338.2786,N,07309.1117,E,0.10,290.51,040511,,A*66
$GPVTG,290.51,T,,M,0.10,N,0.2,K,N*0E
$GPGGA,190814.583,3338.2788,N,07309.1132,E,1.03,1.5,39.2,M,-39.2,M,,0000*4F
$GPGSA,A,2,17,05,12,,,,,,,,,1.8,1.5,1.0*3F
$GPRMC,190814.583,A,3338.2788,N,07309.1132,E,0.08,297.47,040511,,A*61
$GPVTG,297.47,T,,M,0.08,N,0.1,K,N*04
$GPGGA,190815.583,3338.2795,N,07309.1133,E,1.03,1.5,39.2,M,-39.2,M,,0000*43
$GPGSA,A,2,17,05,12,,,,,,,,,1.8,1.5,1.0*3F
$GPGSV,3,1,11,12,50,318,47,17,20,075,43,05,20,168,40,02,80,247,29*79
$GPGSV,3,2,11,04,53,043,43,10,38,116,,09,34,240,32,27,30,227,27*7B
$GPGSV,3,3,11,25,11,316,34,29,03,277,24,28,00,135,*4C
$GPRMC,190815.583,A,3338.2795,N,07309.1133,E,0.08,292.60,040511,,A*6D
$GPVTG,292.60,T,,M,0.08,N,0.2,K,N*07
$GPGGA,190816.583,3338.2792,N,07309.1129,E,1.03,1.5,39.2,M,-39.2,M,,0000*4C
$GPGSA,A$GPGGA,193806.000,3338.2247,N,07309.1944,E,1.10,0.8,494.6,M,-39.2,M,,000
0*77
$GPGSA,A,3,17,05,04,12,27,09,02,25,29,10,,,1.5,0.8,1.3*3B
$GPRMC,193806.000,A,3338.2247,N,07309.1944,E,0.11,24.89,040511,,,A*50
$GPVTG,24.89,T,,M,0.11,N,0.2,K,A*38
$GPGGA,193807.000,3338.2248,N,07309.1944,E,1.10,0.8,494.6,M,-39.2,M,,0000*79
$GPGSA,A,3,17,05,04,12,27,09,02,25,29,10,,,1.5,0.8,1.3*3B
$GPRMC,193807.000,A,3338.2248,N,07309.1944,E,0.07,38.38,040511,,,A*5E
$GPVTG,38.38,T,,M,0.07,N,0.1,K,A*3B

Disconnected Auto detect 4800 8-N-1 SCROLL CAPS NUM Capture Print echo
```



Interfacing GSM with MICROCONTROLLER

GSM SIM900D Features

- Frequency 1800 MHz
- Voltage 3.5 V – 4.5 V
- Current 40 mA
- Baud rate 4800,9600
- SMS Sending/Receiving
- Voice Calls
- GPRS supported

Simulations (Proteus)

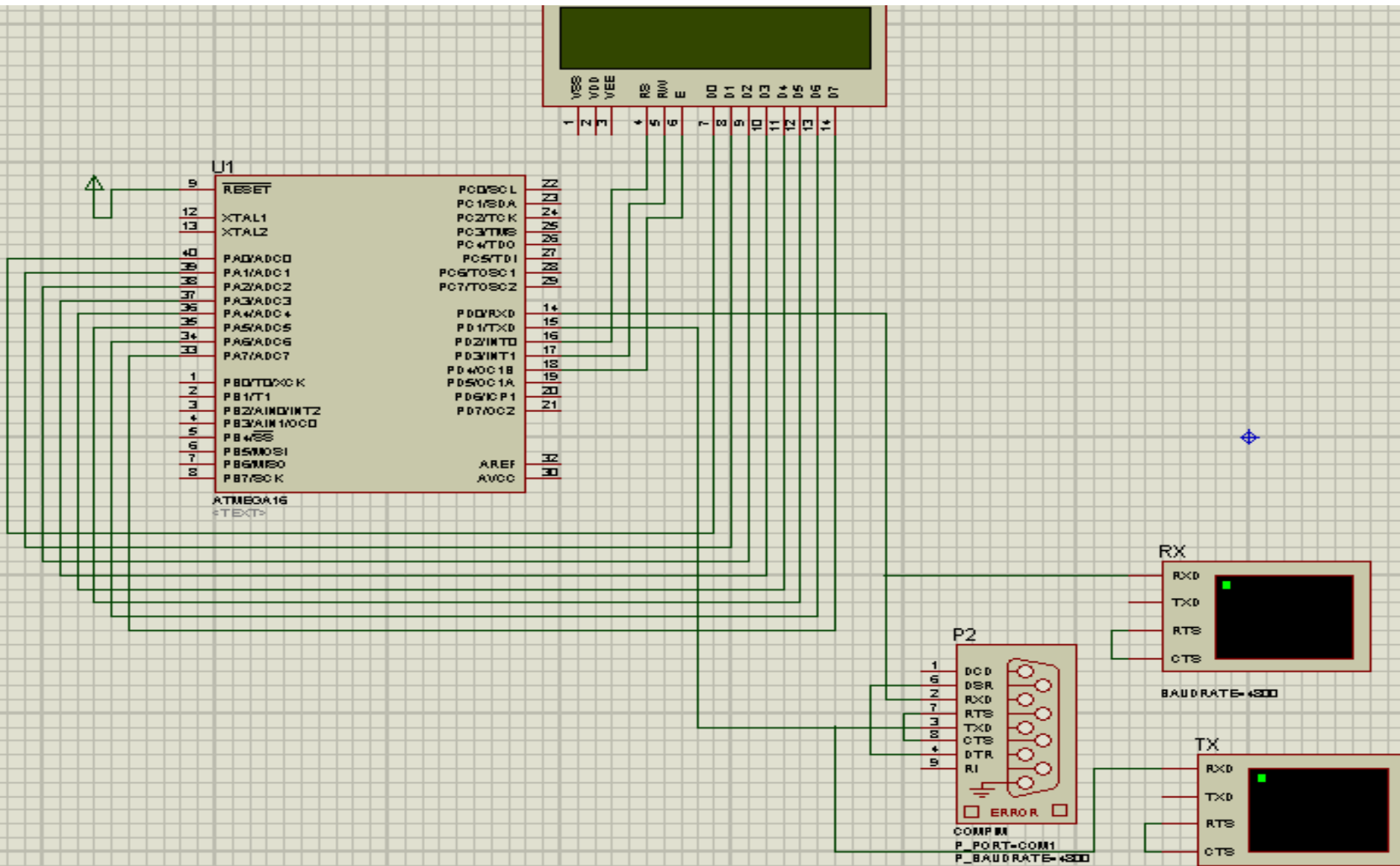

Hyper Terminal (Results)

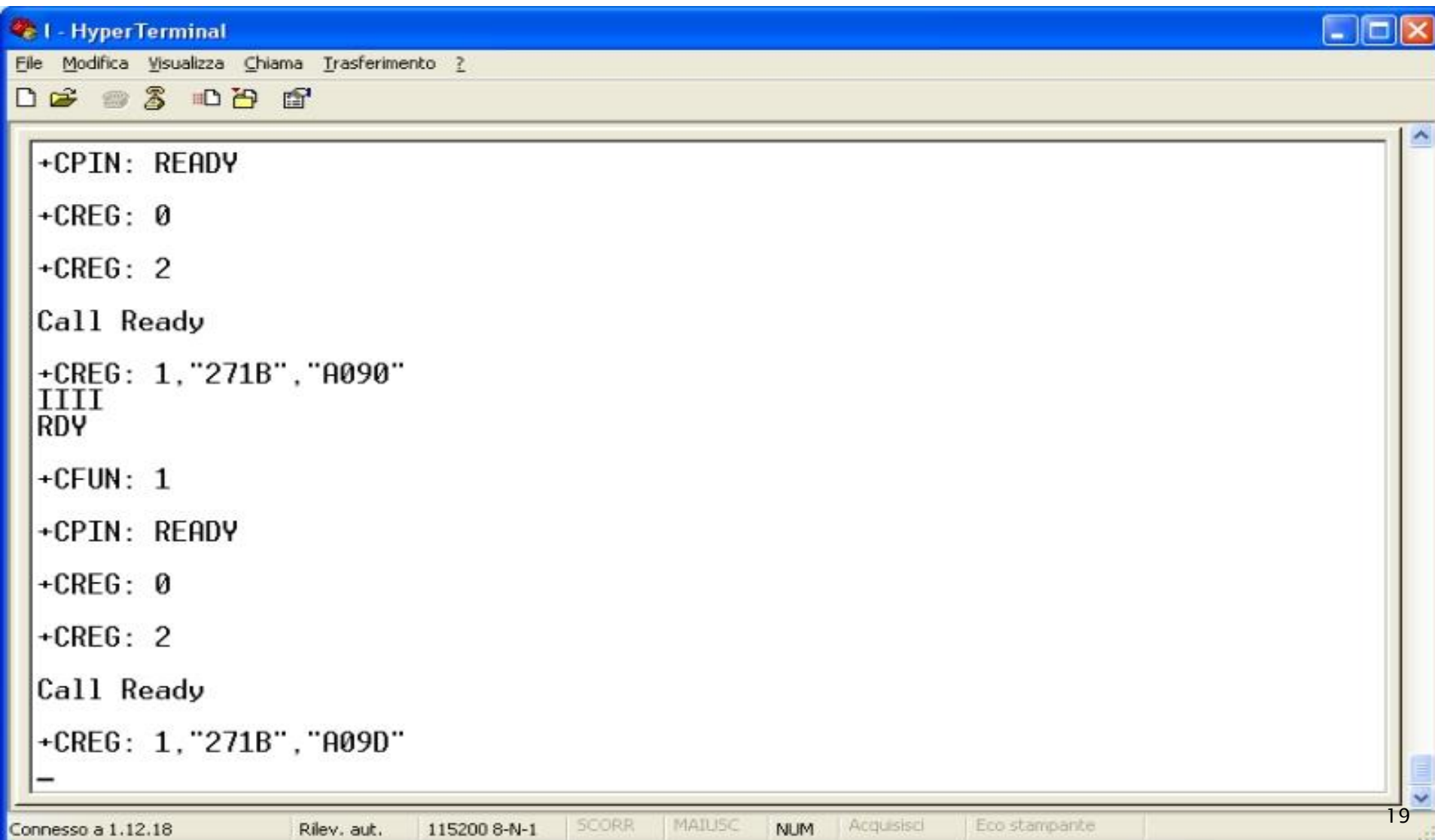

The image shows a HyperTerminal window with a blue title bar and a menu bar. The main area contains the following text:

```
+CPIN: READY
+CREG: 0
+CREG: 2
Call Ready
+CREG: 1,"271B","A090"
IIII
RDY
+CFUN: 1
+CPIN: READY
+CREG: 0
+CREG: 2
Call Ready
+CREG: 1,"271B","A090"
_
```

At the bottom of the window, there is a status bar with the following text: Connesso a 1.12.18, Rilev. aut., 115200 8-N-1, SCORR, MAIUSC, NUM, Acquisisci, Eco stampante.

Microcontroller Programming

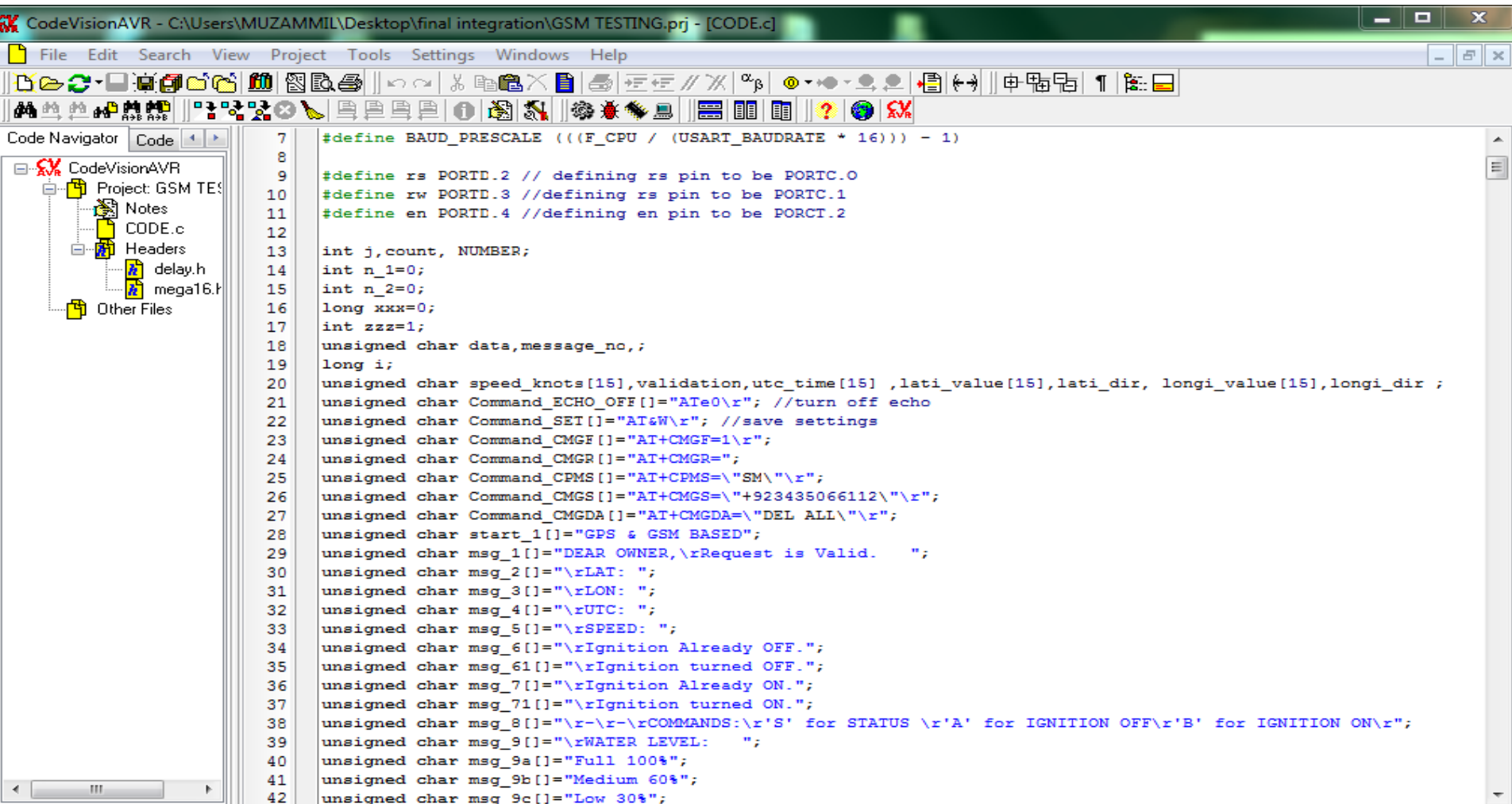

The screenshot shows the CodeVisionAVR IDE interface. The title bar indicates the project path: "CodeVisionAVR - C:\Users\MUZAMMIL\Desktop\final integration\GSM TESTING.prj - [CODE.c]". The menu bar includes File, Edit, Search, View, Project, Tools, Settings, Windows, and Help. The toolbar contains various icons for file operations and development tools. The Code Navigator on the left shows the project structure: CodeVisionAVR, Project: GSM TE..., Notes, CODE.c, Headers, delay.h, mega16.h, and Other Files. The main editor displays the following C code:

```
7 #define BAUD_PRESCALE (((F_CPU / (USART_BAUDRATE * 16))) - 1)
8
9 #define rs PORTD.2 // defining rs pin to be PORTC.0
10 #define rw PORTD.3 //defining rs pin to be PORTC.1
11 #define en PORTD.4 //defining en pin to be PORCT.2
12
13 int j, count, NUMBER;
14 int n_1=0;
15 int n_2=0;
16 long xxx=0;
17 int zzz=1;
18 unsigned char data,message_no,;
19 long i;
20 unsigned char speed_knots[15],validation,utc_time[15] ,lati_value[15],lati_dir, longi_value[15],longi_dir ;
21 unsigned char Command_ECHO_OFF[]="ATe0\r"; //turn off echo
22 unsigned char Command_SET[]="AT&W\r"; //save settings
23 unsigned char Command_CMGF[]="AT+CMGF=1\r";
24 unsigned char Command_CMGR[]="AT+CMGR=";
25 unsigned char Command_CPMS[]="AT+CPMS=\\"SM\\" \r";
26 unsigned char Command_CMGS[]="AT+CMGS=\\"+923435066112\\" \r";
27 unsigned char Command_CMGDA[]="AT+CMGDA=\\"DEL ALL\\" \r";
28 unsigned char start_1[]="GPS & GSM BASED";
29 unsigned char msg_1[]="DEAR OWNER,\rRequest is Valid.  ";
30 unsigned char msg_2[]="\rLAT: ";
31 unsigned char msg_3[]="\rLON: ";
32 unsigned char msg_4[]="\rUTC: ";
33 unsigned char msg_5[]="\rSPEED: ";
34 unsigned char msg_6[]="\rIgnition Already OFF.";
35 unsigned char msg_61[]="\rIgnition turned OFF.";
36 unsigned char msg_7[]="\rIgnition Already ON.";
37 unsigned char msg_71[]="\rIgnition turned ON.";
38 unsigned char msg_8[]="\r-\r-\rCOMMANDS:\r'S' for STATUS \r'A' for IGNITION OFF\r'B' for IGNITION ON\r";
39 unsigned char msg_9[]="\rWATER LEVEL:  ";
40 unsigned char msg_9a[]="Full 100%";
41 unsigned char msg_9b[]="Medium 60%";
42 unsigned char msg_9c[]="Low 30%";
```

Messages

Switching Board Schematic

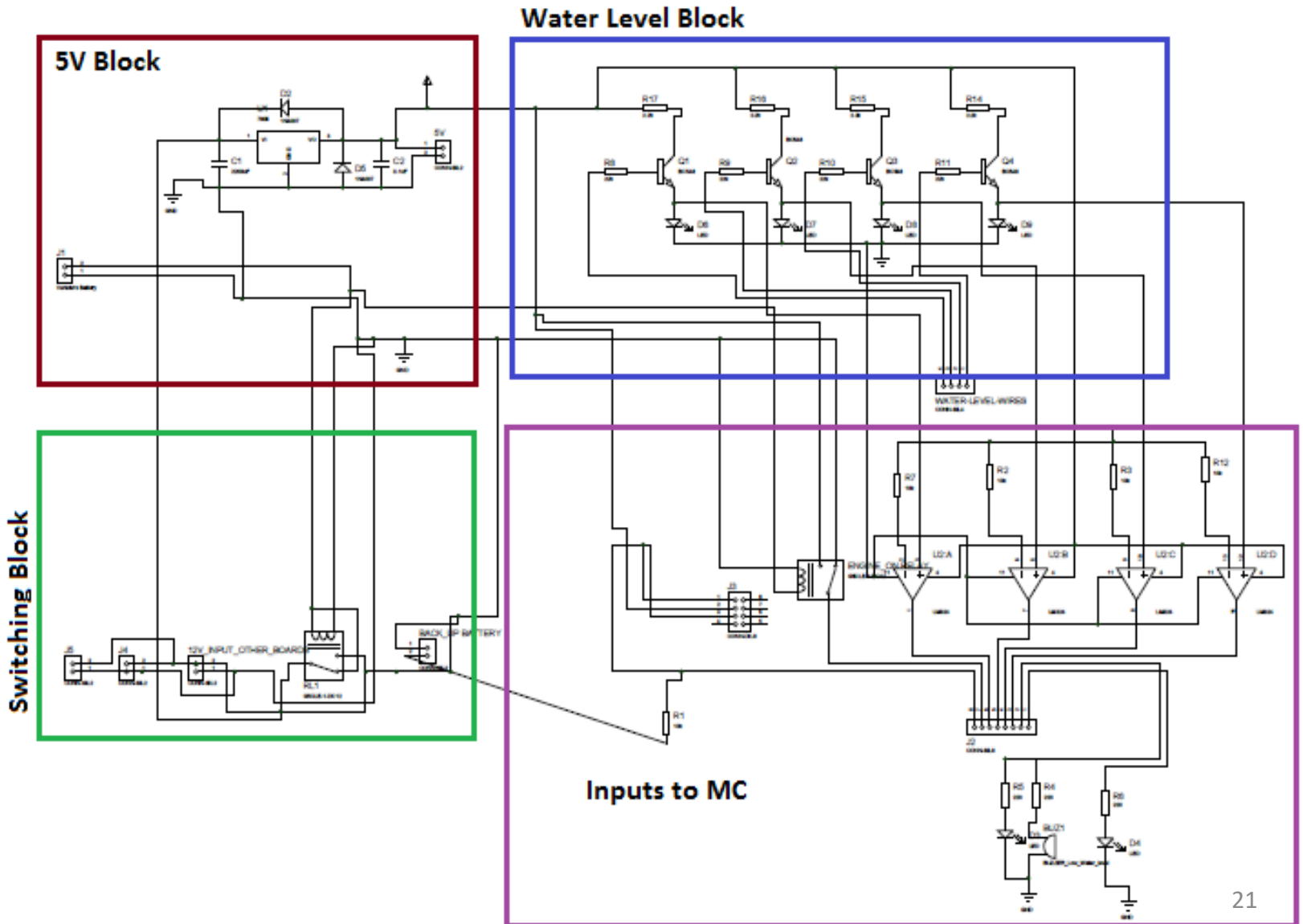

GSM Board Schematic

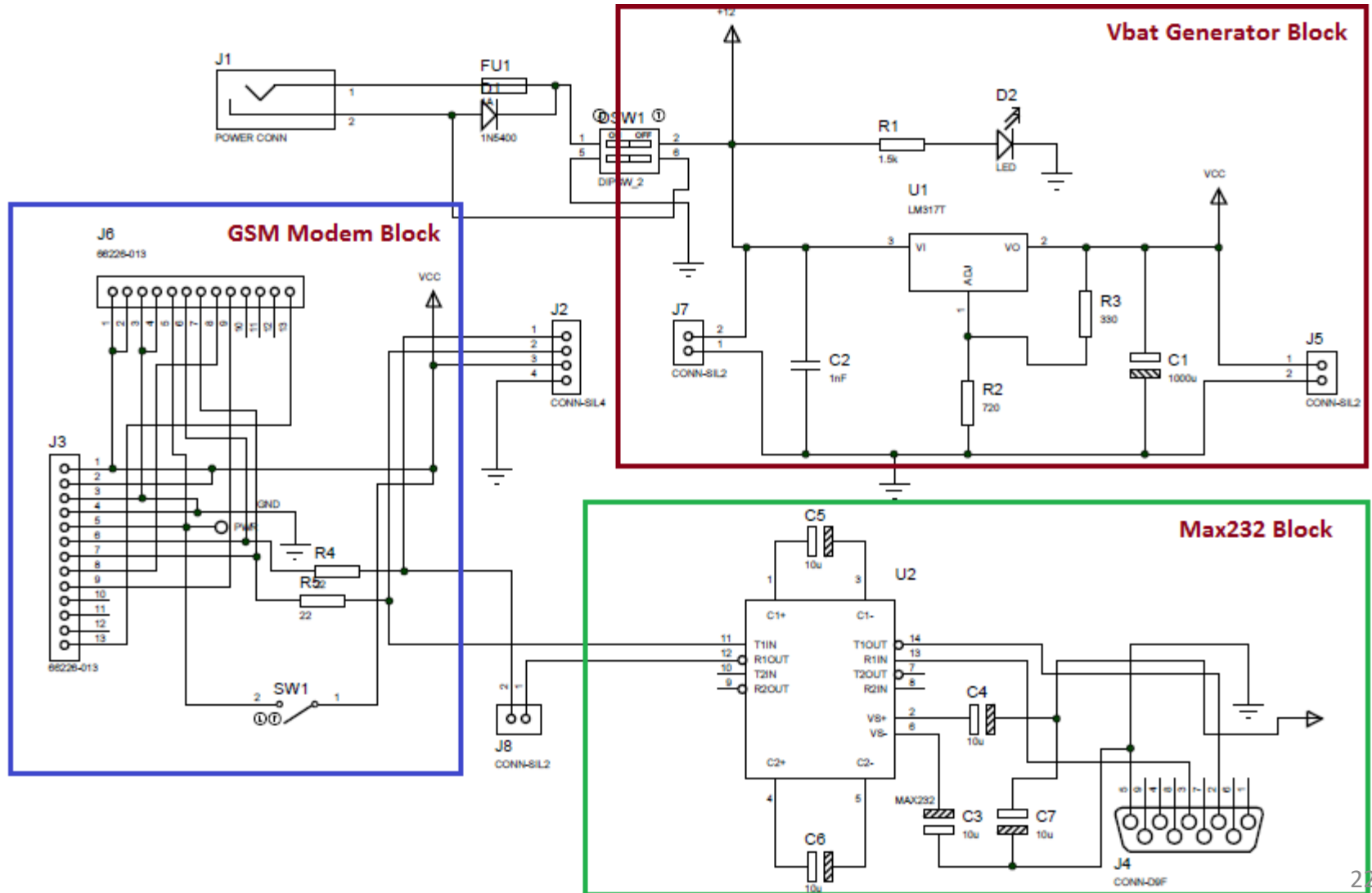

GPS Board Schematic

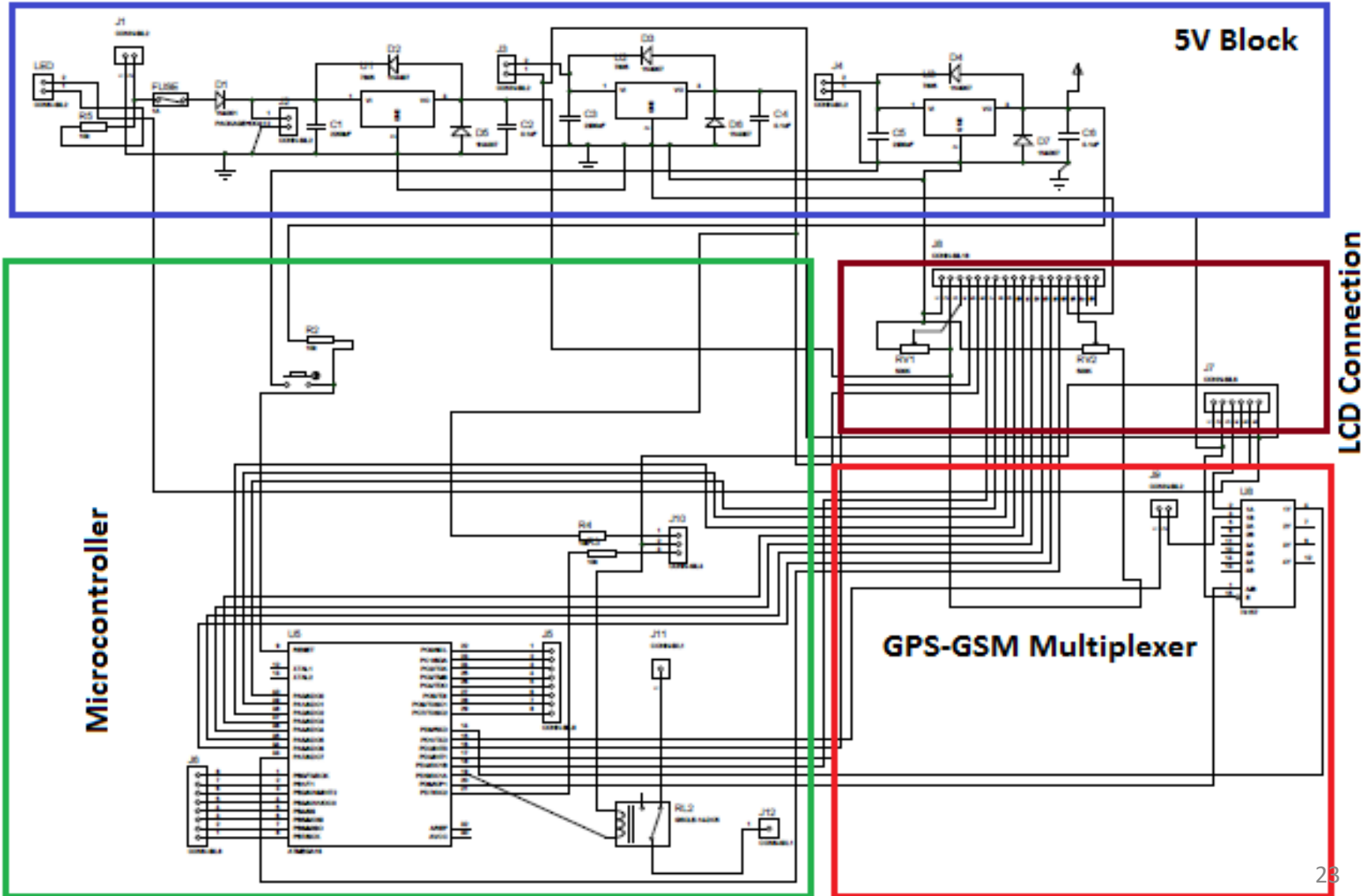

Features

NO THIRD PERSON

TRACKING

BACK UP BATTERY

PUSH BUTTON SECURITY

ENGINE SWITCH OFF

WATER LOW LEVEL ALARM/SMS

AREA RESTRICTION/SMS

BATTERY DISCONNECTION SMS

PORTABLE

WATER LEVEL

ECONOMICAL

FULL CONTROL OF VEHICLE

Final Hardware Product

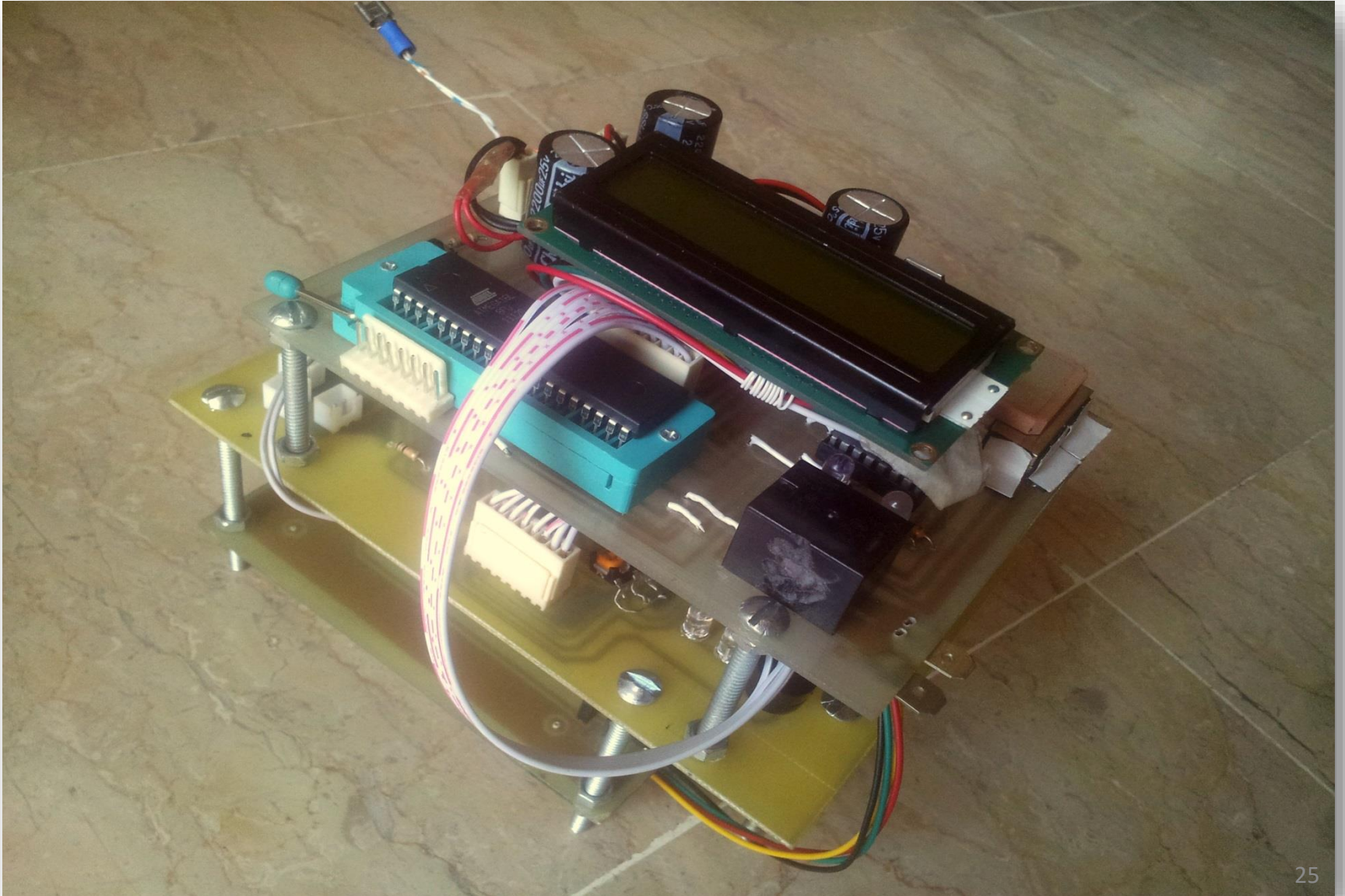

Android Application



Website Portal



Email:
Password:
[Sign In](#)

HOME

ABOUT

SERVICES

REGISTER

Best Security For your mobiles



Welcome to Our Company!

This is the place where you can have a very close look at your vmobile asset(s)!

We proudly presents our Vehicle tracking system through which you can easily track you vehicle and also you can see the movements of your vehicle on the map shown here in our services tab!

Do you want your mobile asset to be safe? Do you want your mobile asset to be controlled by you? Do you want a close look of your mobile asste? If your answer to all these questions is YES, the DO contact us!

Achievements

- Selected in TOP 5 Engineering Projects of CIIT in HEC Annual Project Exhibition 2013.



Higher Education Commission Pakistan

- Selected in TOP 10, out of 100, Best Business Ideas in Punjab PLAN9 Incubator Program 2012.



- Being one of the best Commercial Project, We were called on ATV for live interview with Farah Khan.



Future Work

Commercializing the Product

Interfacing with Police 15

SMD Card Interfacing

FH Spread Spectrum for Anti-Jamming

Encryption Algorithms for Data Security

Thank you!
James

